

Level Sensors with Magnetic Floats



APPLICATIONS

- Liquid container monitoring in household appliances, automotive applications, test and measurement, and control technology.

FEATURES

- High power switches available
- Other cables, connectors and colors available
- Form A (normally open) and Form B (normally closed) types are available
- IP 68 (only to screw thread)

DESCRIPTION

Standard liquid level sensor. The sensor has to be mounted horizontally for best results.

Two versions are available:

PP (Polypropylene) for water applications and dilute acids

PA (Polyamide) for use in oil, gasoline (petrol) and brake fluid

The standard termination is a PVC cable with a cross section of 0.14 mm² and a length of 500 mm. The cable can be modified on request.

MATERIALS

Materials PA version	
Shaft, nut	Polyamide black
Float	Polyamide black
Seal	Nitrile rubber
Materials PP version	
Shaft, nut	Polypropylene black
Float	Polypropylene black
Seal	Nitrile rubber

DIMENSIONS

All dimensions in mm [inches]

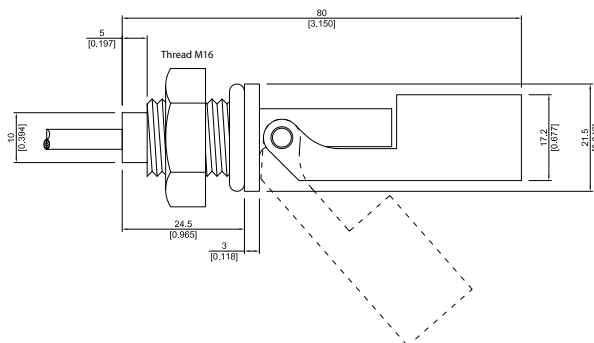

MOVEMENT

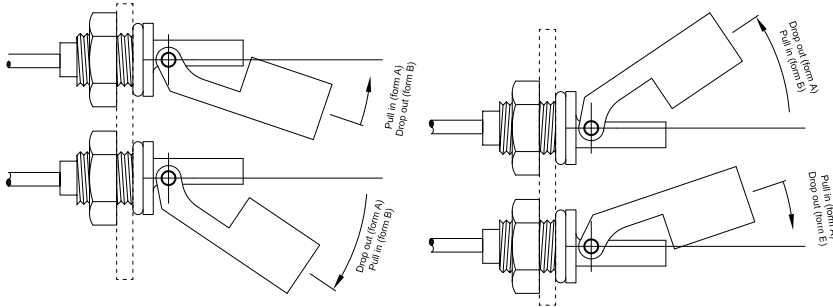

ORDER INFORMATION

Part Number Example

LS03 - 1A66 - PA - 500 W

1A is the contact form

66 is the switch model

PA is the material

500 is the cable length (mm)

W is the termination

Series	Contact Form	Switch Model	Material	Cable Length (mm)	Termination
LS03 -	XX	XX -	XX -	XXX	X
Options	1 Form A	66, 84	PA, PP	500 *	W
	1 Form B				
* Other cable lengths available.					

TERMINATION

For wire and termination details please contact factory.

W		The cable cut length includes: 5 mm of wire stripped and tinned
----------	--	--

Level Sensors with Magnetic Floats

CONTACT DATA

All Data at 20° C	Switch Model --> Contact Form -->	Switch 66 Form A			Switch 84 Form A / B			Units
		Min.	Typ.	Max.	Min.	Typ.	Max.	
Switching Power	Any DC combination of V & A not to exceed their individual max.'s			10			10	W
Switching Voltage	DC or peak AC			200			400	V
Switching Current	DC or peak AC			0.5			0.5	A
Carry Current	DC or peak AC			1.25			1.0	A
Static Contact Resistance	w/ 0.5 V & 10 mA			150			150	mΩ
Dynamic Contact Resistance	Measured w/ 0.5 V & 50 mA , 1.5 ms after closure			200			200	mΩ
Insulation Resistance across Contacts	100 volts applied	10 ¹⁰ *			10 ¹¹			Ω
Breakdown Voltage across Contact	Voltage applied for 60 sec. min.	225 *			700			VDC
Operation Time incl. Bounce	Measured w/ 50 % overdrive			0.5			2.0	ms
Release Time	Measured w/ no coil suppression			0.1			0.1	ms
Capacitance	at 10 kHz cross contact		0.2			0.7		pF
Environmental Data								
Shock Resistance	1/2 sinus wave duration 11 ms			50			50	g
Vibration Resistance	From 10 - 2000 Hz			20			20	g
Ambient Temperature	10°C/ minute max. allowable	-20		90	-20		90	°C
Stock Temperature	10°C/ minute max. allowable	-20		100	-20		100	°C
Soldering Temperature	5 sec. dwell			260			260	°C
Please note: The indicated electrical data are maximum values and can vary downwards when using a more sensitive switch. * Insulation resistance of 10 ¹² and breakdown voltage of 480 VDC is available. These ranges refer to the uncut / unmodified Reed Switches described in our Reed Switch section. Consult factory if more detail is required.								